



FW-IOB-D-120/240VAC

Input/Output/Bypass Assembly

Installation Instructions



The OutBack Power Systems FW-IOB-D-120/240VAC allows manual switching between the FX Series Inverter/Charger and a second AC source, facilitating maintenance and power continuity.

About OutBack Power Systems

OutBack Power Systems is a leader in advanced energy conversion technology. Our products include true sine wave inverter/chargers, a maximum power point charge controller, system communication components, as well as breaker panels, breakers, accessories, and assembled systems.

Notice of Copyright

FW-IOB-D-120/240VAC Installation Instructions
Copyright © 2006 All rights reserved.

Disclaimer

UNLESS SPECIFICALLY AGREED TO IN WRITING, OUTBACK POWER SYSTEMS:
(a) MAKES NO WARRANTY AS TO THE ACCURACY, SUFFICIENCY OR SUITABILITY OF ANY TECHNICAL OR OTHER INFORMATION PROVIDED IN ITS MANUALS OR OTHER DOCUMENTATION.
(b) ASSUMES NO RESPONSIBILITY OR LIABILITY FOR LOSS OR DAMAGE, WHETHER DIRECT, INDIRECT, CONSEQUENTIAL OR INCIDENTAL, WHICH MIGHT ARISE OUT OF THE USE OF SUCH INFORMATION. THE USE OF ANY SUCH INFORMATION WILL BE ENTIRELY AT THE USER'S RISK.

Date and Revision

November 5, 2008 REV C

Contact Information

OutBack Power Systems
19009 62nd Ave. NE
Arlington, WA 98223
Phone (360) 435-6030 • Fax (360) 435-6019
www.outbackpower.com

Requirements and Warnings

The OutBack FW-IOB-D-120/240VAC is intended as a component for OutBack listed UL508A or UL1741 AC Industrial Control Panels. It is intended for indoor use only.

Grounding Instructions – The frame of this enclosure should be connected to a grounded, permanent wiring system. The AC and DC circuits are not bonded to the FLEXware chassis. System grounding, when required by sections 690.41, 690.42, and 690.43 of the National Electric Code, ANSI/NFPA 70, is the responsibility of the installer. All installations should comply with all national and local codes and ordinances.

The equipment ground is marked with this symbol: 

FW-IOB-D-120/240VAC Parts List

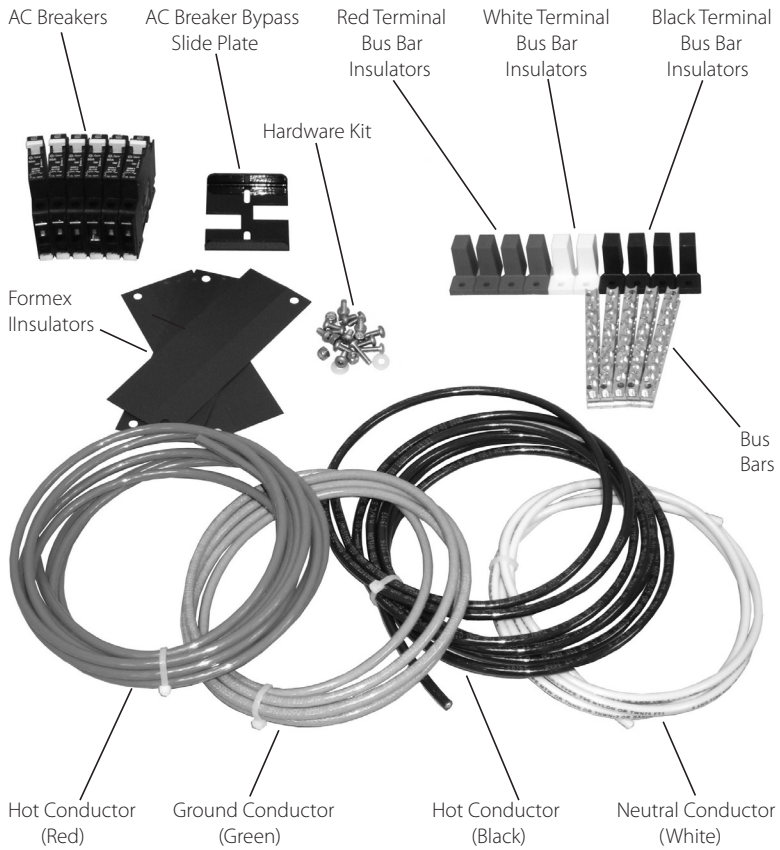

Figure 1: FW-IOB-D-120/240VAC

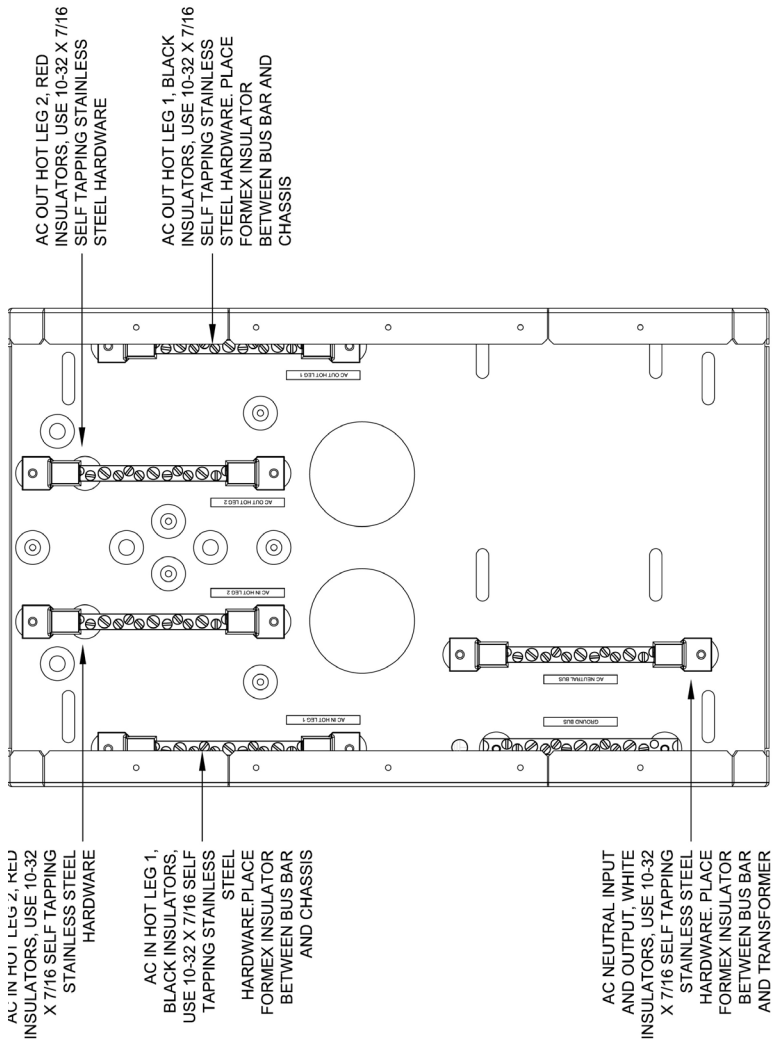

Figure 2: Placement of Bus Bars

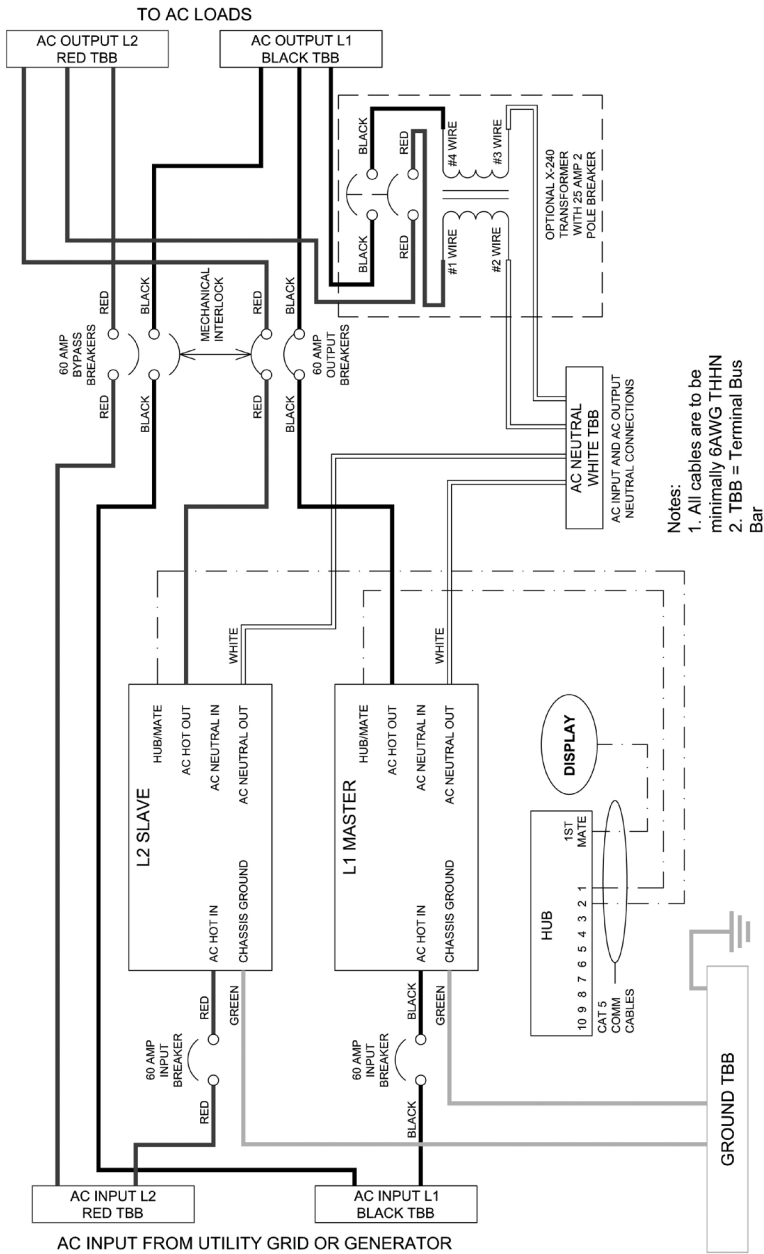

Figure 3: Sample Wiring Diagram

Installing the FW-IOB-D-120/240VAC

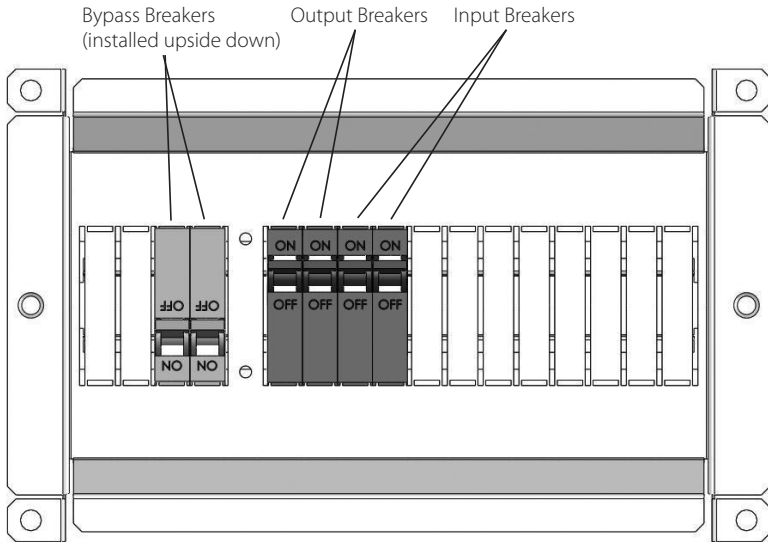

Figure 4: AC Breaker Installation for FW-IOB-D-120/240VAC

To install the FW-IOB-D-120/240VAC:

- Remove the appropriate quantity of breaker knockouts from the breaker bracket.
- Pull the yellow tabs out from each breaker.
- Install the breakers on the DIN rail to approximately match the openings in the breaker bracket.
- Hold the breaker bracket loosely against the breakers on the DIN rail; move the breakers as needed so they line up with the openings in the breaker bracket.
- With the breakers positioned properly, lock the yellow tabs to secure the breakers to the DIN rail.
- Install the AC Breaker Bypass Slide Plate (see Figure 5).

Installing the AC Breaker Bypass Slide Plate

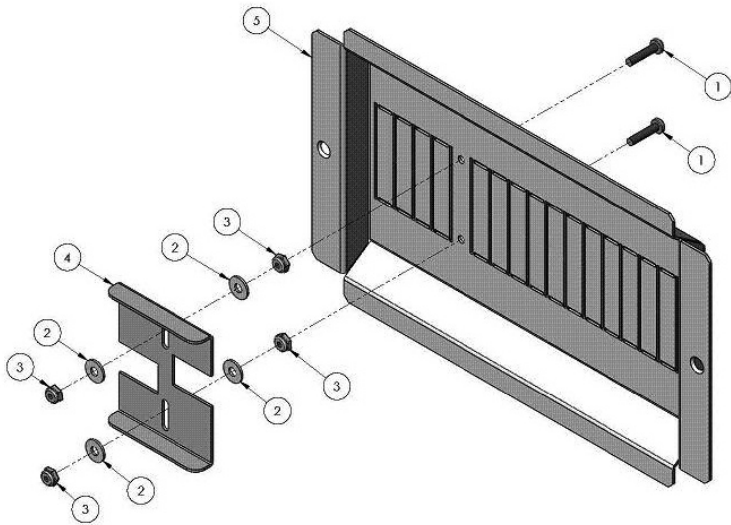

Figure 5: AC Breaker Bypass Slide Plate Installation

Parts:

1. 8-32 X .75 Machine Screw (2)
2. Nylon Washer (4)
3. 8-32 Nylock Nut (4)
4. AC Breaker Bypass Slide Plate (1)
5. FLEXware AC Breaker Bracket (1)

To Assemble:

- Remove necessary circuit breaker knockouts (per IOB kit).
- Install AC Breaker Bypass Slide Plate and fasteners as shown in Figure 5.
- Do not overtighten the Nylock nuts. Overtightening can cause the AC Breaker Bypass Slide Plate to bind.



Corporate Office
19009 62nd Avenue NE
Arlington, WA USA
(+1) 360-435-6030

European Sales Office
C/ Castelló, 17
08830 - Sant Boi de Llobregat
BARCELONA, España
Phone: +34.93.654.9568

www.outbackpower.com

900-0069-01-00 REV C